



131 County Rd. 34E
Jackson, MN 56143
www.hitchdoc.com

Telephone 1-800-446-8222
507-847-4049
Fax 507-847-5100
questions@hitchdoc.com

HD Road Glide/Ultra Hitch '09-'13

H15230 Installation Instructions

ALWAYS CHECK BOLT LENGTH FOR TIRE CLEARANCE

This hitch is designed for a completely stock motorcycle. If the rear shocks, suspension, or tire have been adjusted/changed in any way, it is up to the customer to verify that there isn't any interference between the hitch and any part of the motorcycle.

These instructions are written as you are installing the hitch from the back of the bike so "left" would refer to the roadside and "right" would refer to the curbside.

Have a friend help with installing the hitch. We recommend that you use "Loctite" (blue) on all bolts so that they do not come loose during your ride.

Read all instructions carefully before attempting installation. Do not fully tighten fasteners until installation is complete, unless instructed to do so.

1. Unpack the hitch and verify that all parts and fasteners are present and free of defects. Refer to the included hitch drawing to help identify the parts included with the hitch.
2. (Optional) Install the mud flap/safety chain bracket [Item 20, H19904] using the 1/4"-20 x 1" hex bolts [Item 8, H17019], 1/4" flat washers [Item 7, H17008], 1/4" lock washers [Item 5, H17003] and 1/4" hex nuts [Item 6, H17004].
3. Locate the chrome strut cover on the right side of the bike. Remove the seat strap bolt and the 5/16" Torx head bolt holding on the strut cover. Repeat for the left side.
4. Remove the radio antenna and bracket, a new relocation bracket [Item 1, H15210 300] will be used instead. Follow the wiring for the taillight in the extension up under the seat and disconnect. Next, loosen the three nuts on each side of the extension and one on the inside of the fender just behind the tire. Remove the extension.
5. Locate the three mounting points for the hitch that were under the chrome cover which was removed in Step 3. Slide the hitch into place from the rear of the motorcycle, locate it on top of the steel strut and line up the three holes. It may be necessary to spread the hitch side arms to get it over the mounts. Two people are strongly suggested for this step. Install (2) 5/16"-18 x 1" hex head bolts [Item 13, H17104] and (2) 1/4" flat washers [Item 7, H17008] on each side of the hitch as shown in the hitch drawing and leave loose for adjustment.

6. Reinstall the plastic fender extension that was removed in Step 4 and reconnect wiring for the taillight.
7. Check the hitch for clearance on the fender of the motorcycle and the plastic fender extension. Adjust and center as desired and tighten the four 5/16" hex bolts from step 5.
8. Reinstall the chrome strut cover with the new 5/16"-18 x 1-1/4" button head bolt [*Item* 10, H17040] and the 5/16" flat washer [*Item* 9, H17039] between the cover and the hitch. Install the bushing [*Item* 15, H17512] between the cover and the strut at the seat strap location. Tighten all bolts and repeat for the other side.
9. Install the antenna relocation bracket [*Item* 1, H15210 300] on the left side of the motorcycle hitch arm with (2) #10-24 x 1/2" socket head cap screws [*Item* 12, H17042] and #10-24 hex nuts [*Item* 11, H17041]. Reinstall the radio antenna to the new bracket.
10. Install the left support bracket [*Item* 3, H15230 400] and the right support bracket [*Item* 2, H15230 300] using a 5/16"-18 x 1/2" button head screw [*Item* 14, H17118] with a 5/16" flat washer [*Item* 9, H17039].
11. Insert the shaft of the chrome receiver [*Item* 19, H18030C] up into the bottom of the chrome receiver bracket and temporarily insert the receiver pin [*Item* 16, H17890C] through the holes of both parts (it doesn't matter which side of the bracket the pin is inserted). To remove excess rattle, tighten the 3/8"-24 x 3/4" rattle bolt [*Item* 18, H17903] on the front side of the hitch (behind the tire). Keep tightening until when you remove the pin, the receiver stays in place. Now, holding onto the bottom of the receiver, slowly loosen the bolt (about a quarter turn or less) until the receiver is able to be removed from the hitch. Reinsert the receiver and the pin and secure it by inserting the hair pin clip [*Item* 17, H17899] into the hole in the end of the pin by pushing firmly until the middle of the clip is over the pin.

It is the operator's responsibility to periodically check all fasteners/mounting hardware to ensure none have come loose during use and to check for any signs of wear.

Thank you for purchasing a quality hitch made by HitchDoc, Mfg. Enjoy!

H15230 HD ROAD GLIDE/ULTRA '09-'13

ITEM NO.	PART NUMBER	QTY.	DESCRIPTION
1	H15210 300	1	ANTENNA MOUNT
2	H15230 300	1	SUPPORT BRACKET, RIGHT
3	H15230 400	1	SUPPORT BRACKET, LEFT
4	H15230C	1	CHROME HITCH
5	H17003	2	WASHER, 1/4" SPLIT-LOCK, ZN
6	H17004	2	NUT, 1/4"-20 HEX, ZN
7	H17008	8	WASHER, 1/4" FLAT USS, ZINC
8	H17019	2	BOLT, 1/4"-20 X 1 HEX, GR5 ZN
9	H17039	4	WASHER, 5/16" FLAT, CHROME
10	H17040	2	BOLT, 5/16"-18 X 1-1/4 BHHEX, CHROME
11	H17041	2	NUT, 10-24 HEX, ZN
12	H17042	2	BOLT, 10-24 X 1/2 SHCS, ZN
13	H17104	4	BOLT, 5/16"-18 X 1 HEX, GR5 ZN
14	H17118	2	SCREW, 5/16"-18 X 1/2 BHHEX, CHROME
15	H17512	2	BUSHING, 0.70 OD X 0.33 ID X 0.16, CHROME
16	H17890C	1	RECEIVER PIN, SHORT
17	H17899	1	HAIR PIN, 3/32" X 1-1/4, ZINC
18	H17903	1	BOLT, 3/8"-24 X 3/4 HEX, ZN (RATTLE BOLT)
19	H18030C	1	RECEIVER, 1-1/2" OFFSET, CHROME
20	H19904	1	TOW HOOK/MUDFLAP BRACKET

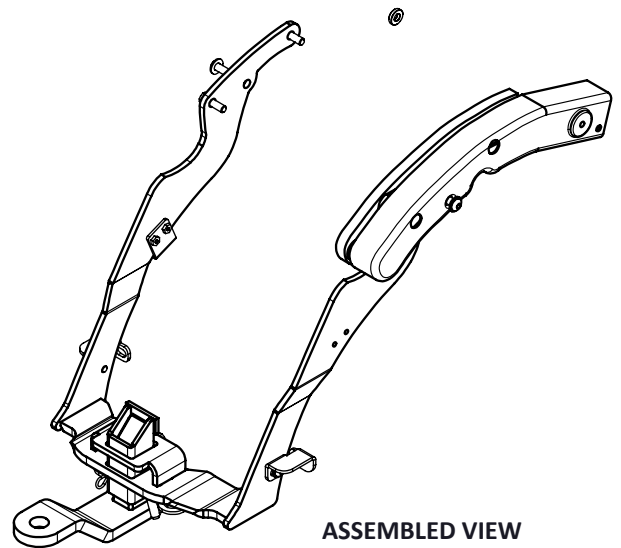

MOUNTING HARDWARE IS THE SAME ON EACH SIDE OF HITCH EXCEPT FOR ITEMS 1, 11, 12

