



131 County Rd. 34E.  
Jackson, MN 56143  
www.hitchdoc.com

Telephone 1-800-446-8222  
507-847-4049  
Fax 507-847-5100  
questions@hitchdoc.com

## 2014+ Harley Davidson Ultra Classic, Ultra-Limited (Low), Road Glide Ultra, Road King H15225 Installation Instructions

**\*ALWAYS CHECK BOLT LENGTH FOR TIRE CLEARANCE\***

**This hitch is designed for a completely stock motorcycle. If the rear shocks, suspension, or tire have been adjusted/changed in any way, it is up to the customer to verify that there isn't any interference between the hitch and any part of the motorcycle.**

These instructions are written as you are installing the hitch from the back of the bike, so "left" would refer to the roadside and "right" would refer to the curbside.

Have a friend help with installing the hitch. We recommend that you use "Loctite" (blue) on all bolts so that they do not come loose during your ride.

Read all instructions carefully before attempting installation. Do not fully tighten bolts until installation is complete, unless instructed to do so.

1. Unpack the hitch and verify that all parts and fasteners are present and free of defects. Refer to the included hitch drawing to help identify the parts included with the hitch.
2. Locate the chrome strut cover on the right side of the bike. Remove the two 5/16" Torx head bolts that go through the strut cover. Repeat for the left side of the bike. Place the longer chrome spacer (Item 12) in the hole where the front most bolt was removed from on either side. Insert the shorter chrome spacer (Item 11) in the hole where the rear most bolt was removed from on either side. When installed, the spacers should basically be flush with the chrome strut.
3. Two people are recommended for this step: Slide the hitch [Item 3, H15225] into place from the rear of the motorcycle and spread the arms to go over the chrome strut lining the two holes in the hitch arms up with the location of the bushings that were just installed. Place a 5/16" chrome flat washer [Item 8, H17039] on all four of the 5/16" x 1-3/4" chrome button head bolts [Item 18, HDW813]. Insert each of the bolts through the holes in the hitch, through the chrome bushings, through the chrome strut cover, and thread into the bike frame. Do not fully tighten.
4. Locate the saddle bag mount bracket on the right side of the bike toward the rear of the fender. Remove the 5/16" Torx bolt closest to the fender. Keep this bolt, it will be reinstalled. Install the right support bracket [Item 2, H15225 500] to the right hitch arm using

the 5/16" x 3/4" hex bolt [Item 9, H17101], 5/16" chrome flat washer [Item 8, H17039] and 5/16" chrome acorn nut [Item 10, H17113]. Attach the rear part of the bracket to the saddle bag bracket re-using the 5/16" Torx bolt that was just removed. Do not fully tighten. Repeat for the left side of the bike using the left support bracket [Item 1, H15225 400]. Do not fully tighten.

5. Check the hitch for clearance on the fender of the motorcycle, clearance on the tire, and underneath the fender for tail light clearance. Adjust and center the hitch as needed and then fully tighten all of the hardware working in a criss-cross pattern to keep the hitch straight.
6. (Optional) Install the mud flap/safety chain bracket [Item 17, H19904] using the 1/4"-20 x 1" hex bolts [Item 7, H17019], 1/4" flat washers [Item 6, H17008], 1/4" lock washers [Item 4, H17003], and 1/4" hex nuts [Item 5, H117004].
7. Insert the shaft of the chrome receiver [Item 16, H18050C] up into the bottom of the painted receiver bracket and temporarily insert the receiver pin [Item 13, H17890C] through the holes of both parts (it doesn't matter which side of the bracket the pin is inserted). To remove excess rattle, tighten the 3/8"-24 x 3/4" rattle bolt [Item 15, H17903] on the front side of the hitch (behind the tire). Keep tightening until when you remove the pin, the receiver stays in place. Now, holding onto the bottom of the receiver, slowly loosen the bolt (about a quarter turn or less) until the receiver is able to be removed from the hitch. Reinsert the receiver and the pin and secure it by inserting the hair pin clip [Item 14, H17899] into the hole in the end of the pin by pushing firmly until the middle of the clip is over the pin.

It is the operator's responsibility to periodically check all fasteners/mounting hardware to ensure none have come loose during use and to check for any signs of wear.

Thank you for purchasing a quality hitch made by HitchDoc, Mfg. Enjoy!

# H15225 HD ULTRA LIMITED 2014 HITCH

ITEM NO.	PART NUMBER	QTY.	DESCRIPTION
1	H15225 400	1	SUPPORT BRACKET, LEFT
2	H15225 500	1	SUPPORT BRACKET, RIGHT
3	H15225C	1	HITCH WLDMT, LIMITED '14
4	H17003	2	WASHER, 1/4" SPLIT-LOCK, ZN
5	H17004	2	NUT, 1/4"-20 HEX, ZN
6	H17008	4	WASHER, 1/4" FLAT, ZN
7	H17019	2	BOLT, 1/4"-20 X 1 HEX, GR5 ZN
8	H17039	6	WASHER, 5/16" FLAT, CHROME
9	H17101	2	BOLT, 5/16"-18 X 3/4 HEX, ZINC
10	H17113	2	ACORN NUT, 5/16"-18 HEX, CHROME
11	H17522	2	BUSHING, 0.68 OD X 0.41 ID X 0.26, CHROME
12	H17547	2	BUSHING, 0.63 OD X 0.33 ID X 0.63, CHROME
13	H17890C	1	RECEIVER PIN, SHORT
14	H17899	1	HAIR PIN, 3/32" X 1-1/4, ZINC
15	H17903	1	BOLT, 3/8"-24 X 3/4 HEX, ZN (RATTLE BOLT)
16	H18050C	1	RETRO REC'R WLDMT, 6" X 1-1/2" OFFSET
17	H19904	1	TOW HOOK/MUDFLAP BRACKET
18	HDW813	4	BOLT, 5/16"-18X1-3/4 BTHD, CHROME

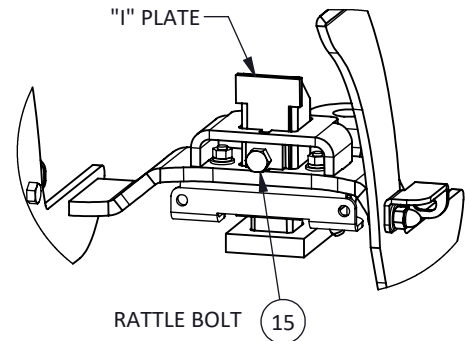

PARTIAL FRONT VIEW OF ASSEMBLED HITCH

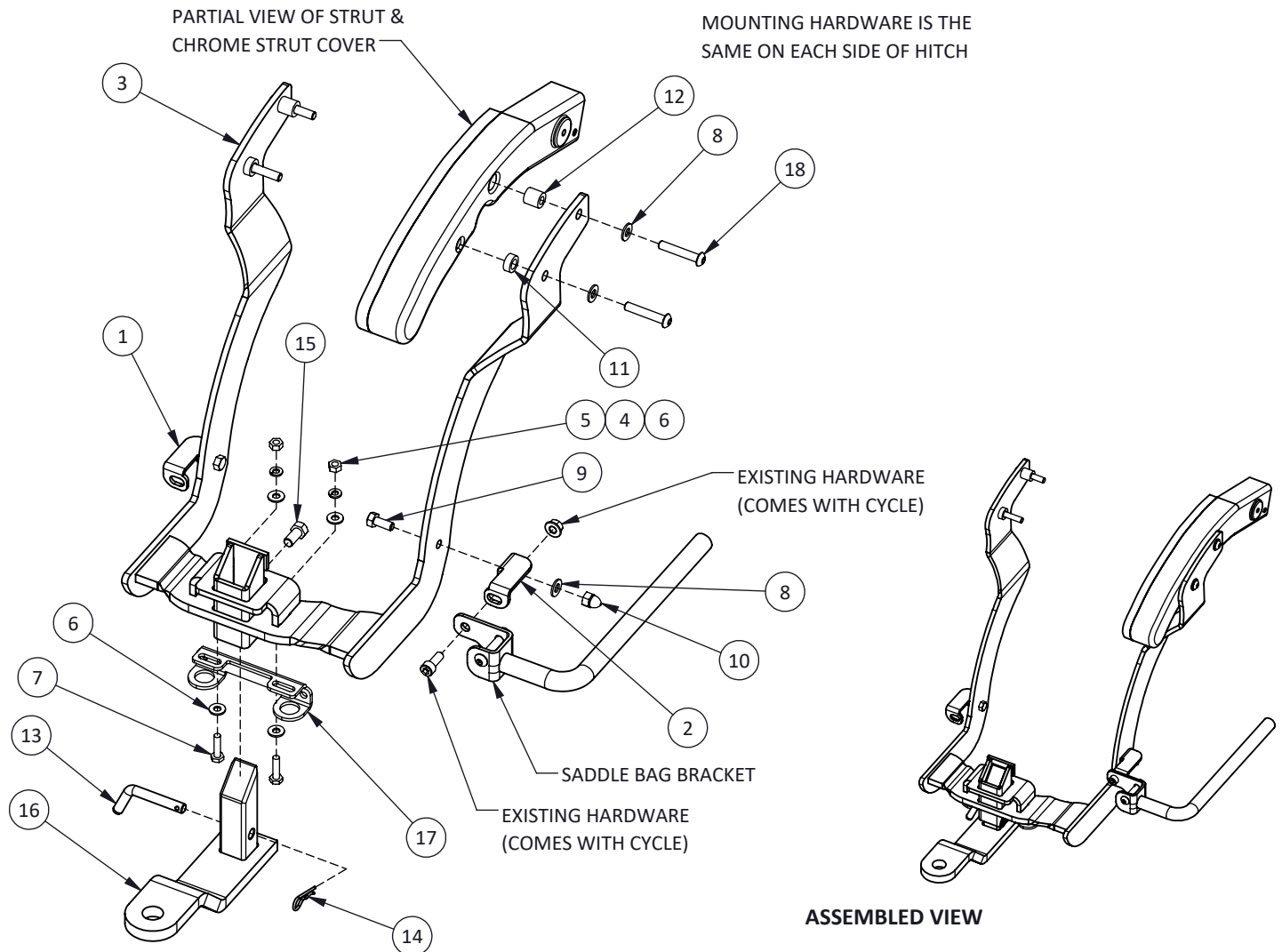

HDW2618  
REVC ECO 1611

REPRODUCTION IN PART OR AS A WHOLE WITHOUT THE WRITTEN PERMISSION OF HITCHDOC, MFG. IS PROHIBITED.

**\*ALWAYS CHECK BOLT LENGTH FOR TIRE CLEARANCE\***