



131 County Rd. 34E
Jackson, MN 56143
www.hitchdoc.com

Telephone 1-800-446-8222
507-847-4049
Fax 507-847-5100
questions@hitchdoc.com

Heritage Springer 2000-2002 H15159 Installation Instructions

ALWAYS CHECK BOLT LENGTH FOR TIRE CLEARANCE

This hitch is designed for a completely stock motorcycle. If the rear shocks, suspension, or tire have been adjusted/changed in any way, it is up to the customer to verify that there isn't any interference between the hitch and any part of the motorcycle.

Have a friend help with installing the hitch. We recommend that you use "Loctite" (blue) on all bolts so that they do not come loose during your ride.

These instructions are written as you are installing the hitch from the back of the bike so "left" would refer to the roadside and "right" would refer to the curbside.

Read all instructions carefully before attempting installation. Do not fully tighten fasteners until installation is complete, unless instructed to do so.

1. Unpack the hitch and verify that all parts and fasteners are present and free of defects. Refer to the included hitch drawing to help identify the parts included with the hitch.
2. (Optional) Install the mud flap/safety chain bracket [Item 11, H19903] using the 1/4"-20 x 1" hex bolts [Item 5, H17019], 1/4" flat washers [Item 4, H17008], 1/4" lock washers [Item 2, H17003] and 1/4" hex nuts [Item 3, H17004].
3. Slide the hitch into place from the rear of the motorcycle, locate it on top of the side strut and line up the holes. It may be necessary to spread the hitch side arms to get it over the mounts. Two people are strongly suggested for this step. Use the machined bolts [Item 6, H17400] to mount the hitch.
4. Tighten all fasteners. Alternate from right front to left rear, then left front to right rear to help keep the hitch centered on the bike.
5. Insert the shaft of the chrome receiver [Item 10, H18030] up into the bottom of the chrome receiver bracket and temporarily insert the receiver pin [Item 7, H17890C] through the holes of both parts (it doesn't matter which side of the bracket the pin is inserted). To remove excess rattle, tighten the 3/8"-24 x 1/2" rattle bolt [Item 9, H17913] on the front side of the hitch (behind the tire). Keep tightening until when you remove the pin, the receiver stays in place. Now, holding onto the bottom of the receiver, slowly loosen the bolt (about a quarter turn or less) until the receiver is able to be removed from

the hitch. Reinsert the receiver and the pin and secure it by inserting the hair pin clip [Item 8, H17899] into the hole in the end of the pin by pushing firmly until the middle of the clip is over the pin.

It is the operator's responsibility to periodically check all fasteners/mounting hardware to ensure none have come loose during use and to check for any signs of wear.

Thank you for purchasing a quality hitch made by HitchDoc, Mfg. Enjoy!

H15159 HERITAGE SPRINGER '00 - '02

ITEM NO.	PART NUMBER	QTY.	DESCRIPTION
1	H15155C	1	HITCH WLDMT
2	H17003	2	WASHER, 1/4" SPLIT-LOCK, ZN
3	H17004	2	NUT, 1/4"-20 HEX, ZN
4	H17008	4	WASHER, 1/4" FLAT USS, ZINC
5	H17019	2	BOLT, 1/4"-20 X 1 HEX, GR5 ZN
6	H17400	4	SPEC. BOLT, MACH'D, LTH 3.68, ZINC
7	H17890C	1	RECEIVER PIN, SHORT
8	H17899	1	HAIR PIN, 3/32" X 1-1/4, ZINC
9	H17913	1	BOLT, 3/8"-24 X 1/2 HEX, GR5 ZN
10	H18030	1	RECEIVER, 1-1/2" OFFSET, CHROME
11	H19903	1	TOW HOOK/MUDFLAP BRACKET

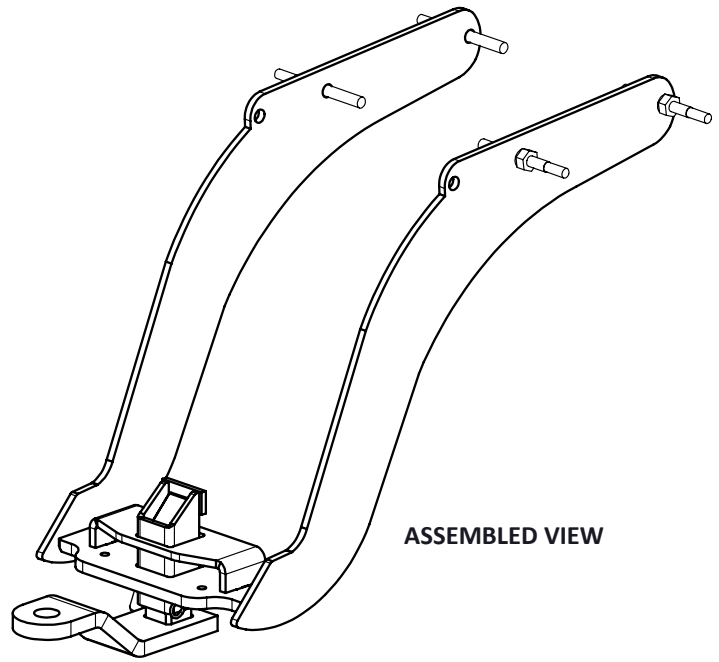

MOUNTING HARDWARE IS THE SAME
EACH SIDE OF THE HITCH

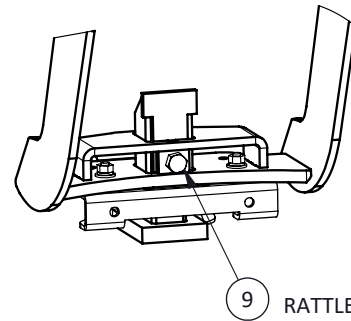
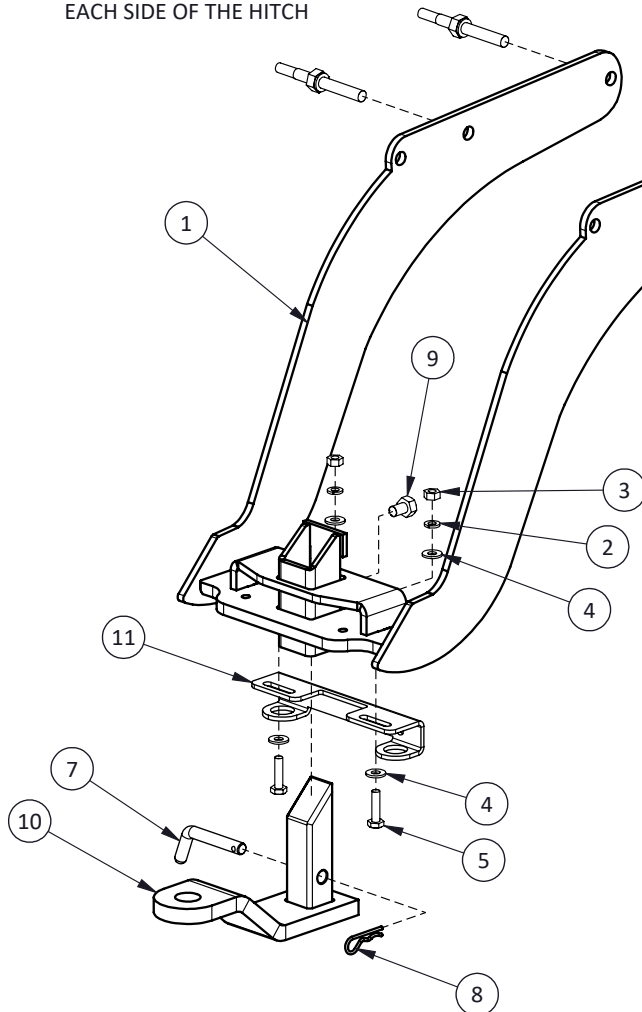

PARTIAL FRONT VIEW OF HITCH ASSEMBLY (BEHIND TIRE)

HDW3109
REVA ECO 1611

REPRODUCTION IN PART OR AS A WHOLE WITHOUT THE WRITTEN PERMISSION OF HITCHDOC, MFG. IS PROHIBITED.

ALWAYS CHECK BOLT LENGTH FOR TIRE CLEARANCE