

H15095 FXST, 06-08, SOFTAIL CUSTOM

ITEM NO.	PART NUMBER	QTY.	DESCRIPTION
1	H15095C	1	2006-2008 FXST HITCH WLDMNT
2	H17003	2	WASHER, 1/4" SPLIT-LOCK, ZN
3	H17004	2	NUT, 1/4"-20 HEX, ZN
4	H17008	4	WASHER, 1/4" FLAT USS, ZINC
5	H17019	2	BOLT, 1/4"-20 X 1 HEX, GR5 ZN
6	H19914	1	TOW HOOK/MUDFLAP BRACKET

REUSE EXISTING BOLTS

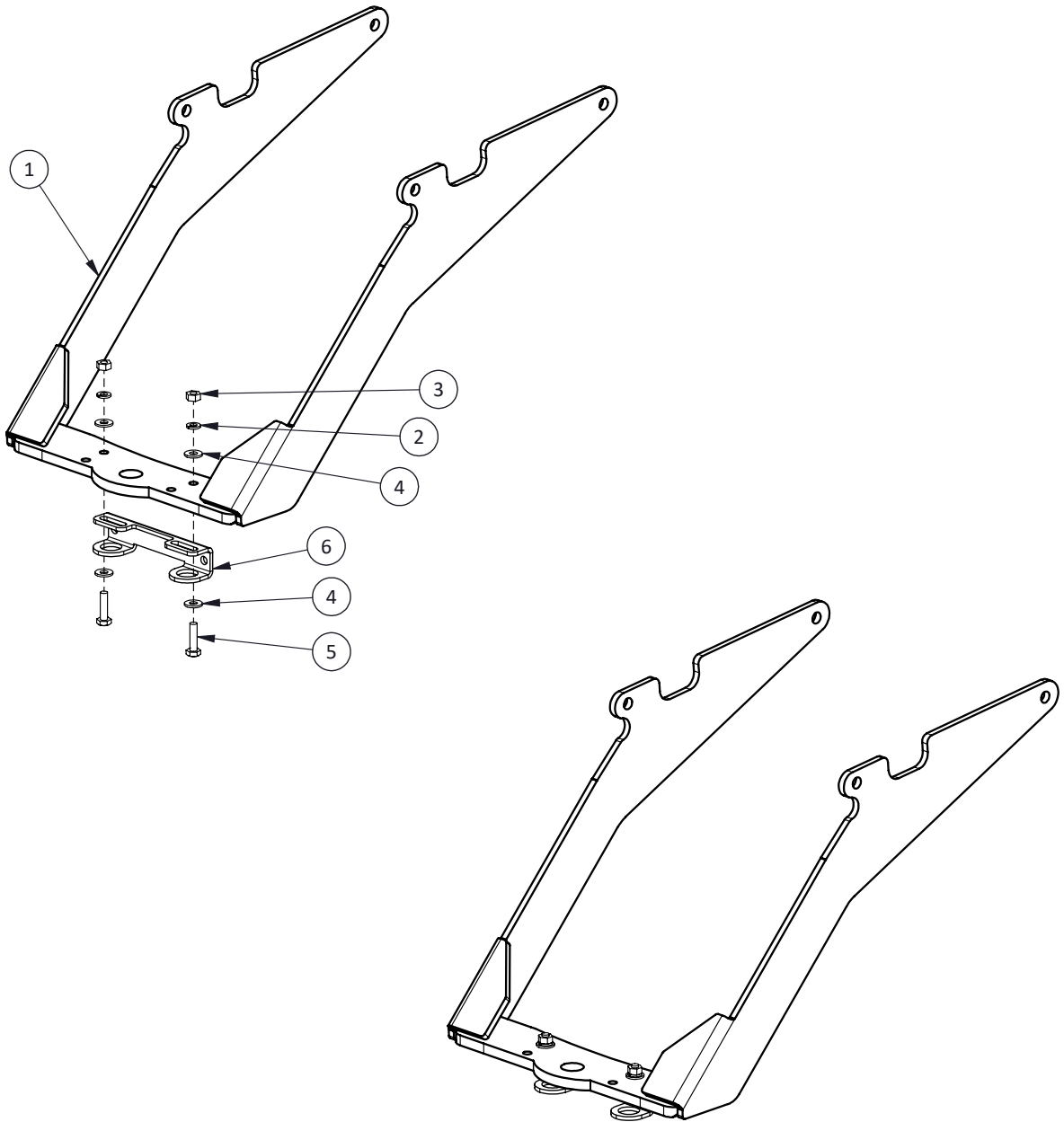

ASSEMBLED VIEW

HDW3098
REVA ECO 1611

REPRODUCTION IN PART OR AS A WHOLE WITHOUT THE WRITTEN PERMISSION OF HITCHDOC, MFG. IS PROHIBITED.

ALWAYS CHECK BOLT LENGTH FOR TIRE CLEARANCE