

H15090 FXST SOFTAIL CUSTOM

ITEM NO.	PART NUMBER	QTY.	DESCRIPTION
1	H15090C	1	FXST/SOFTAIL HITCH
2	H17003	2	WASHER, 1/4" SPLIT-LOCK, ZN
3	H17004	2	NUT, 1/4"-20 HEX, ZN
4	H17008	4	WASHER, 1/4" FLAT USS, ZINC
5	H17019	2	BOLT, 1/4"-20 X 1 HEX, GR5 ZN
6	H19914	1	TOW HOOK/MUDFLAP BRACKET

NOTE:
 2001 AND NEWER MODELS REQUIRE
 A TURN SIGNAL RELOCATION KIT.
 HARLEY DAVIDSON PART #53692-96

MOUNTING HARDWARE IS THE
 SAME ON EACH SIDE OF HITCH

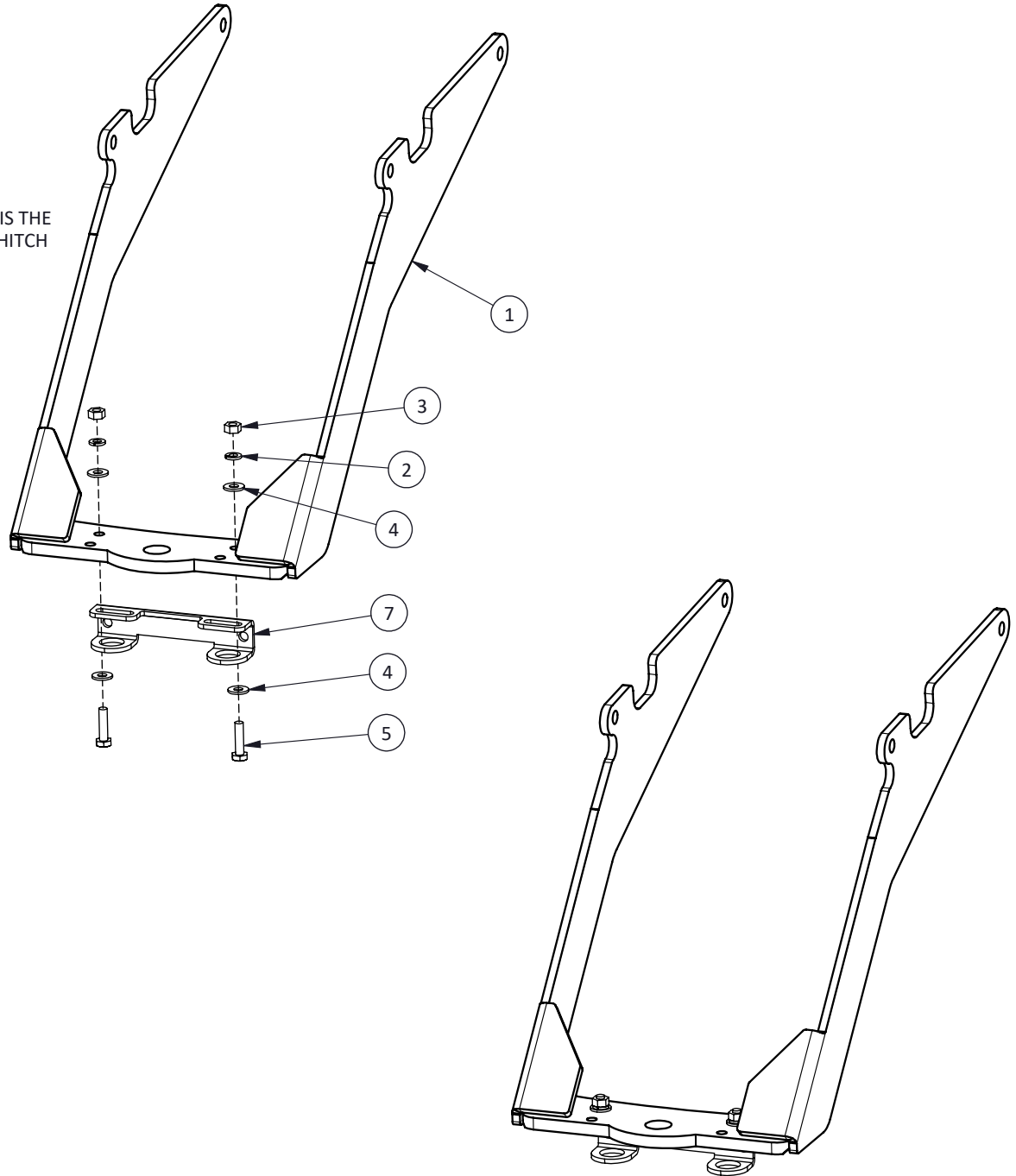

ASSEMBLED VIEW